

MBC

Double Cone Solids Blender



APPLICATION

The double cone blender is used to produce homogeneous solid-solid mixture. Mixing is a common process step in the manufacture of products for industries such as food, cosmetics, pharmaceutical, chemical, detergents, fertilizers and plastics.

Examples of materials or substances mixed in this way include pharmaceutical granules, semolina flour, seeds, starch, coffee beans and ground coffee, cocoa, chocolate flakes or granules, powdered milk, baby food, preparations to make dehydrated soups and creams, leaf waxes, detergent granules, soap flakes, artificial fertilizers, plastic in powder, ground or pellet form, fibreglass, etc.

PRINCIPLE OF OPERATION

The main body of the blender consists of two cone-shaped sections welded at their bases to a central cylindrical section. The axis of rotation is perpendicular to the cone axis and passes through the cylindrical section. The driving motor is located at one of the two lateral supports holding the blender body.

The solids are introduced into the blender through the loading aperture. In this type of blender, mixing takes place axially, as a result of the powder moving through the different sections. Mixing is thorough but it depends on the rotating speed.

The mixture is discharged through a hermetically closing butterfly valve which can be operated manually or automatically.

The unit is provided with a guard rail with electrical safety to prevent the operator from accessing it when in operation. If anyone should gain access to the unit, for safety reasons, the operation will cease.

DESIGN AND FEATURES

The series consists of 6 models with a total capacity of 160 to 4200 litres and a useful capacity of 65% of the total.

This blender is especially designed for sensitive mixtures with risk of breakage where the generation of dusts is to be avoided. Mixing times vary between 5 and 20 minutes depending on the mixture.

There are two apertures: the loading and cleaning aperture, and the discharge opening, which incorporates a butterfly valve that can be operated automatically or manually.

The apertures are sealed hermetically in order to avoid contamination from the outside during the mixing process.

The interior of the blender incorporates a cone mounted on the pivot axis on both sides. This system eliminates the formation of dead spaces and facilitates gravity discharge.

DESIGN AND FEATURES

The unit is manufactured in AISI 316 (EN 14404) quality for all parts in contact with the product and AISI 304 (EN 14301) for the supports and the rest of the equipment. The internal and external surfaces have a bright polished finish.

Due to the polished surface and absence of edges or corners, the unit can be easily cleaned either manually or automatically with CIP system.

The unit incorporates a guard rail with electrical safety, according to EC safety standards.

The motors and electrical panels are available in standard or ATEX protection.

It allows the addition of liquid additives depending on the product to be mixed. Normally, these liquids are added in spray form in order to affect the largest number of particles in the mixture, thereby increasing efficiency.

The system offers a clear added value. The unit's large production capacity, the high quality of the resulting mixture, and the low energy and maintenance costs directly contribute to an increase in profitability.

On request, the loading and discharge systems can be automated with a butterfly valve with pneumatic dosing system.

This equipment has been designed -in contrast to the "V"-type blender- to handle mixtures of granulated products and powders, or mixtures of products with high and different densities, with a loading of 65% of the total capacity of the equipment, unlike the 50% loading in a "V"-type blender, which handles mixtures of powders with the same bulk density.



Vacuum loading port



Vacuum discharge port

MATERIALS

Parts in contact with the product	AISI 316 (EN 14404)
Structure and other metal parts	AISI 304 (EN 14301)
Internal finish	Bright polish
External finish	Bright polish

OPTIONS

This unit allows the incorporation of a liquid spray system to introduce liquids in spray form during the process. The injector is connected to the spray nozzles by means of a rotary system and is fed with additives from a pressurized tank or by means of a variable displacement pump at constant pressure.

The automatic stop positions are: loading, discharging, and sampling. Before stopping at one of these three positions, the system performs a cycle which slows down the mixer in order to reach the stopping position with the highest possible accuracy and remains halted at that point.

The unit can be equipped with an automated loading system for introducing powders and granules into the blender body by means of a vacuum unit with self-cleaning hoses. It prevents creation of dust.

The skid can also be provided with a complete monoblock vacuum unit with liquid ring pump.

It is possible to install an automated vacuum discharge system. It includes a product receiving hopper with an automated self-cleaning filter; as well as a control panel for the unit.

OPTIONS

The loading/discharge can be carried out with pneumatically actuated retractable hermetic bellows. This system and the vacuum loading/discharge can be combined.



Double cone blender with an automatic loading/discharge system



Discharge of the mixed product

GENERAL DIMENSIONS

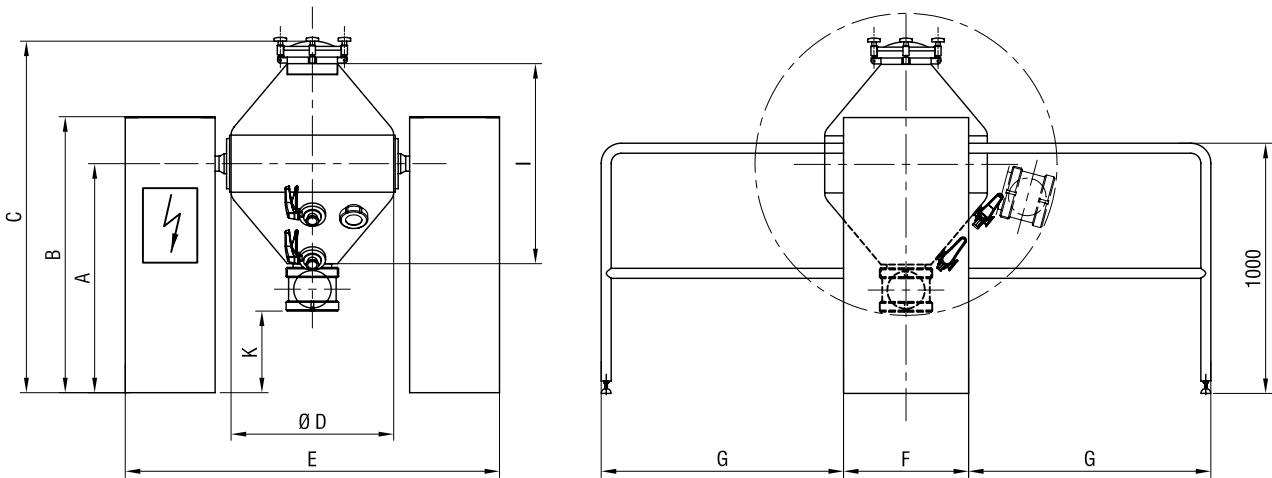

Model	Total Volume (litres)	Useful Volume (litres)	A	B	C	ØD	E	F	G	I	K	kW*	Weight (kg)
MBC160	160	100	1265	1450	1800	650	1500	500	1000	800	600	0,55	810
MBC650	650	400	1540	1725	2350	1000	1850	600	1300	1350	600	1,5	1158
MBC950	950	600	1630	1850	2550	1200	2000	700	1400	1500	600	2,2	1320

* Geared motor

GENERAL DIMENSIONS

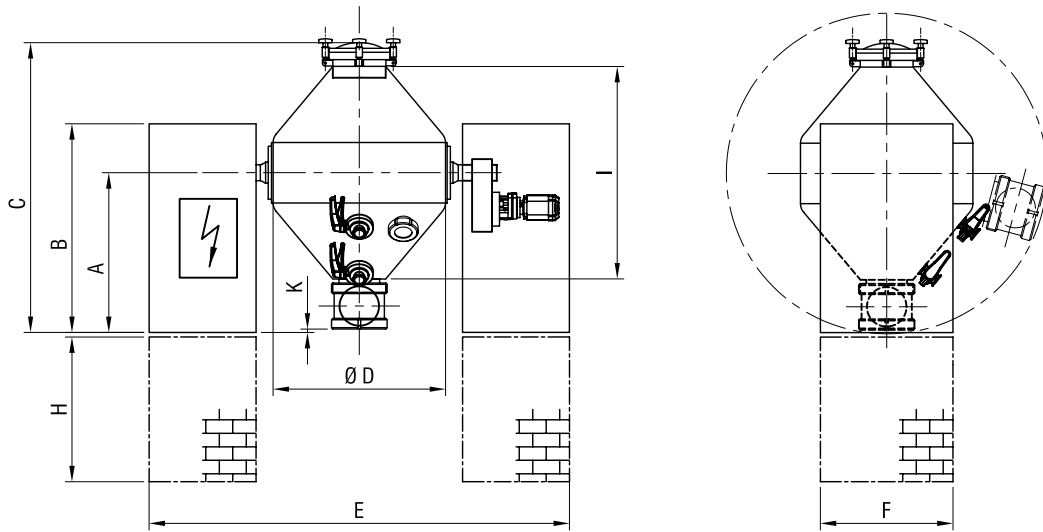

Model	Total Volume (litres)	Useful Volume (litres)	A	B	C	ØD	E	F	H	I	K	kW*	Weight (kg)
MBC1600	1600	1000	1090	1600	2180	1500	3300	1000	as requested	1750	0	3	1800
MBC3000	3000	2000	1350	1850	2700	1700	3500	1000		2220	0	4	2100
MBC4200	4200	2730	1370	1870	2740	2100	4500	1000		2740	0	5,5	2500

* Geared motor

OPTIONS

Vacuum loading system

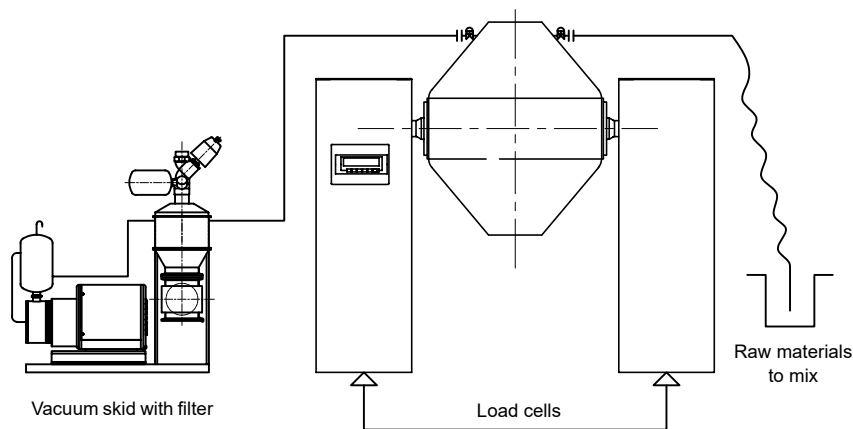

OPTIONS

Vacuum discharge system

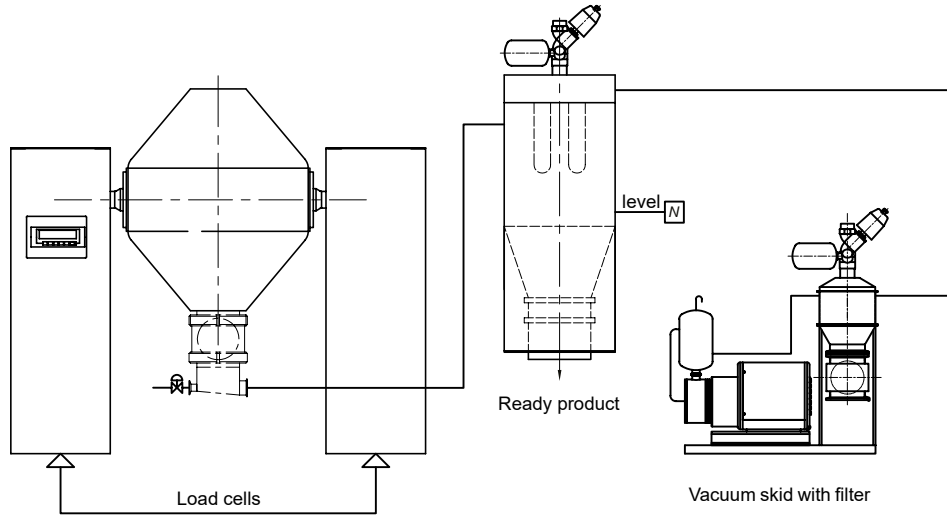

Liquids injection system

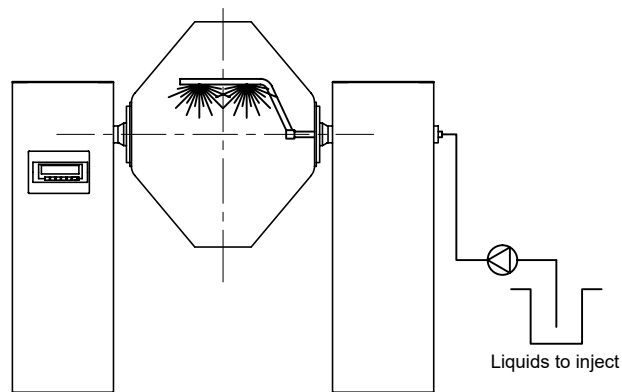

Loading and/or discharge system by gravity, with hermetic retractable bellows

